

ELEVATION VIEW OF ALUMINUM BOX FRAME CANTILEVER
 OUTSIDE LOOKING IN, OPERATOR NOT SHOWN THIS VIEW

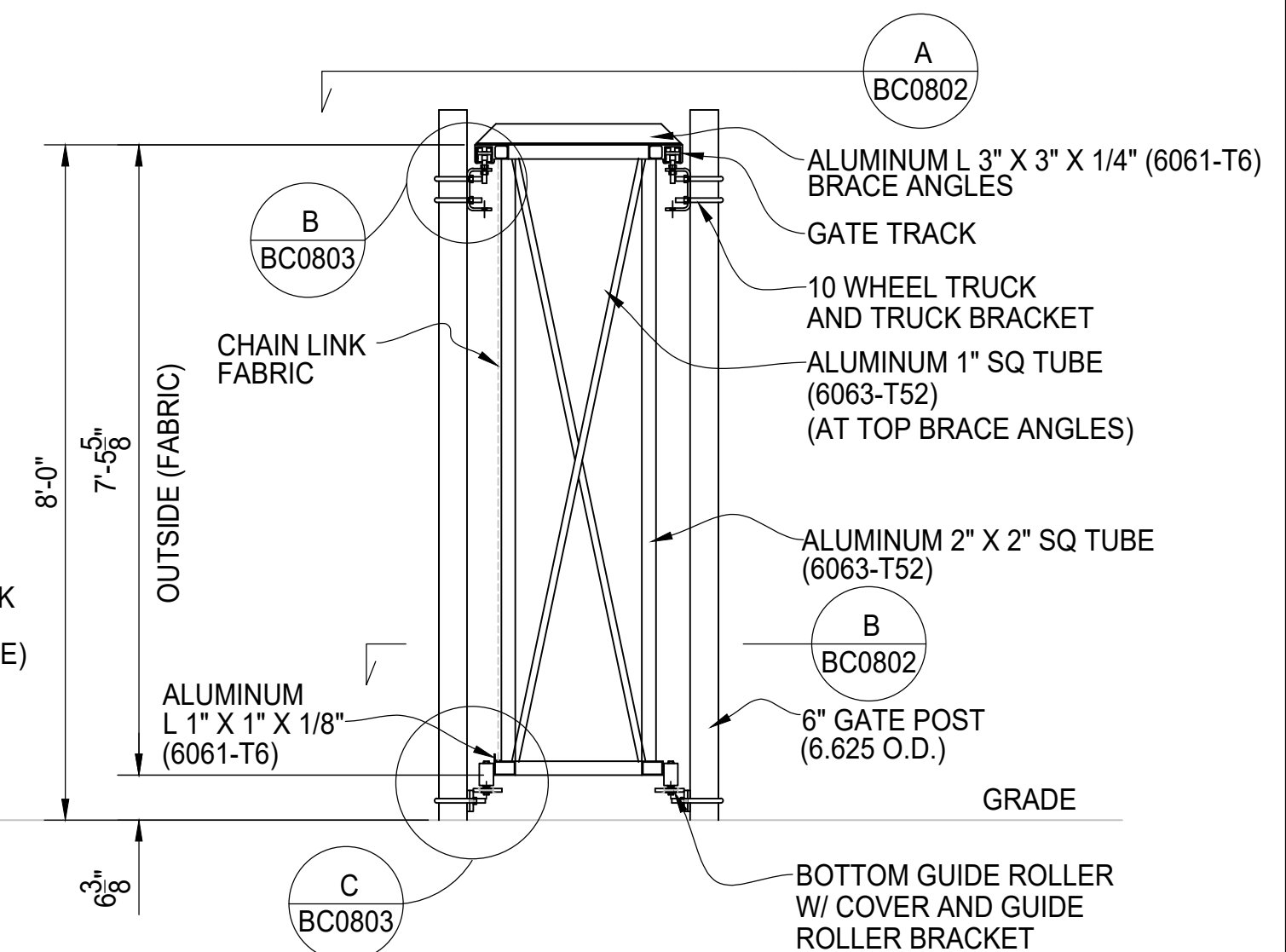

A SECTION VIEW
 OPERATOR NOT SHOWN THIS VIEW

SECTION 02830 Chain Link Cantilever Gates

- PART 1 - GENERAL**
- 01 SECTION INCLUDES:**
- A. The work in this section shall include furnishing all labor, materials, equipment and appliances necessary to complete all Box Framed Cantilever Slide Gate(s) required for this project in strict accordance with this specification section and drawings.
- 02 REFERENCES:**
- A. Underwriters Laboratory Gate Operator Requirements (UL 325). See 3.02 C.
 - 1. Automated/operated vehicular gates are not to be used for pedestrian traffic. Separate pedestrian gates must always be provided if pedestrian traffic is expected.
 - B. ASTM F 2200 - Standard Specification for Automated Vehicular Gate Construction. See 2.01 C.
 - C. ASTM F 1184 - Standard Specification for Industrial and Commercial Horizontal Slide Gates, Type II, Class 2. See 3.02 B.
 - D. American Welding Society AWS D1.2 Structural Welding Code. See 2.01 D and 2.03 D.
- 03 SUBMITTAL:**
- A. Product Data:
 1. Provide manufacturer's catalog cuts with printed specifications and installation instructions.
 2. If operated gate system, furnish two (2) copies of operation and maintenance data covering the installed products.
 - B. Shop Drawings:
 1. Supply shop drawings showing the gate system, including details of all major components.
 2. Include details of gate construction, gate height, and post spacing dimensions.
 - C. Certification of Performance Criteria:
 1. The manufacturer of the gate system shall provide certification stating the gate system includes the following material components that provide the necessary structural performance characteristics capable of supporting the gate through its full range of travel. Alternate designs built to minimum standards that do not include these additional structural features shall not be accepted.
 - a. Gate track system may be a single or as required additional structural extrusion(s) forming a composite structure necessary to support the gate with additional strength when compared to weld only or bolt-on track system.
 - b. Gate shall have a minimum counterbalance length of 50% opening width which provides a 36% increase in lateral resistance (when compared to ASTM minimum of 40% counterbalance). If gate is ever to be automated, counterbalance section shall be filled with fabric or other specified material.

- c. To provide additional structural integrity, intermediate vertical members shall be placed in-between the structural verticals for the full height of the gate framed opening.
 - d. Entire gate frame (including counterbalance section) shall include 2 adjustable stainless or galvanized steel cables (minimum 3/16") per bay to allow complete gate frame adjustment (maintaining strongest structural square and level orientation).
 - e. Gate track assemblies shall be tested for continuous duty and shall have precision ground and hardened components. Bearings shall be pre-lubricated, shock resistant and sealed against outer elements.
 - f. Gate track assemblies shall be supported by a minimum 5/8" plated steel bolt with self-aligning capability, rated to support a 2,500 lb reaction load.
 - g. Hanger brackets shall be hot dipped galvanized steel with a minimum 3/8" thickness. Hanger brackets shall be hot dipped galvanized steel with a minimum 3/8" thickness that is also gusseted for additional strength.
 - h. Gate top track and supporting hanger bracket assemblies shall be certified by a licensed professional engineer to withstand a 2,000 lb. vertical reaction load without exceeding allowable stresses.
- B. Certifications:**
1. Gate in compliance with ASTM F 2200, Standard Specification for Automated Vehicular Gate Construction per section 2.01 C.
 2. If operated gate system, gate operator shall be in compliance with UL 325 as evidenced by UL listing label attached to gate operator.
 3. The aluminum welders and welding process must be certified per section 2.03 D.
 4. Manufacturer shall supply gate design performance certification.
- PART 2 - PRODUCTS:**
- 2.01 CANTILEVER SLIDE GATE MANUFACTURERS:**
- A. The cantilever sliding gate system shall be manufactured by America's Gate Company, 12330 Cary Circle, La Vista Nebraska 68128
 - B. Approved substitution - All other systems must be submitted to the design team in accordance with substitution requirements as set forth in the general provisions of the specification manual for approval prior to the bid date. Products submitted must meet performance criteria. Products submitted after the bid date will not be approved.
 - C. Gate manufacturer shall certify gate is manufactured in compliance with ASTM F 2200, Standard Specification for Automated Vehicular Gate Construction. See 1.03 D.1.
 - D. Upon request, gate manufacturer shall provide independent certification as to the use of a documented Welding Procedure Specification and Procedure Qualification Record to insure conformance to the AWS D1.2 welding code. Upon request, individual Certificates of Welder Qualification documenting successful completion of the requirements of the AWS D1.2 code shall also be provided.

- America's Gate Cantilever Slide Gate dimensions shall be as shown on the detail drawings.
- 2.02 GATE CONSTRUCTION DETAILS:**
- A. Top Track: The frame(s) and track(s) are to be fabricated from aluminum extrusions (6061-T6). Single track applications provide an upper track that weighs 5.15# / foot. Double track applications provide an upper track that weighs 11.916# / ft. The primary members shall be "P" shaped in cross section with no less than 2".
 - B. A single extrusion track member is to be located on each side of the overall box gate frame. The track member is a single extrusion combined with a 2" square structural member. No keying required.
 - C. The single extrusion track and adjoining 2"x2" square structural member are joined with its corresponding track extension by means of perpendicular 2"x2" square members at each vertical upright. 1"x1" square diagonal supports will be placed in-between the perpendicular extrusions as shown.
 - D. When the gate frame is manufactured in two horizontal pieces or sections, they shall be spliced in the field (the gate frame shall be fabricated in one or multiple sections depending on size requirements or project constraints).
 - E. End and Intermediate Vertical Uprights: The vertical uprights shall be a minimum of 2" x 2" x 1.12# / foot (6063-T6) aluminum extrusions.
 - F. Interior vertical members shall alternate between 2"x2" nd 1"x2" running parallel to the face of the gate.
 - G. Diagonal Bracing: Diagonal "X" bracing of 3/16" or 1/4" diameter stainless or galvanized steel cable shall be installed throughout the entire gate frame.
 - H. Bottom Track: The bottom track shall be a minimum of 2" x 2" x 1.12# / foot (6063-T6) aluminum extrusions. For openings greater than 25', the bottom track shall be a minimum of 2" x 5" x 3.12# / foot.
 - I. The gate shall be constructed in "box" form with the width between the frames measuring 24" from outside to outside. Between these frames there shall be a continuous series of 1"x1" diagonal and horizontal bracing with the diagonals welded at approximately 45 degrees to the frames.
 - J. Chain Link: The chain link fabric shall be identical in gauge, mesh, coating and salvage as that used on the balance of the fence project. If the gate stands alone than the fabric shall be specified.
 - K. All welds on the gate frame shall conform to Welding Procedure Specification and Procedure Qualification Record to insure conformance to the AWS D1.2 Structural Welding Code. All individual welders shall be certified to AWS D1.2 welding code. See 1.02 D.
 - L. Gate Mounting:
 1. The gate frame is to be supported from the track by two (2) swivel type, self-aligning, 4-wheeled, sealed lubricant, ball-bearing truck assemblies.

1. The bottom of each support post shall have a bracket equipped with a pair of 3" (76mm) UHMW guide wheels. Wheel cover protectors shall be included with bottom guides to comply with UL325.
 2. Gap protectors shall be provided and installed, compliant with ASTM F 2200-05.
- 2.02 POSTS:**
- A. A single set of support posts shall be minimum 4" O.D. (102mm) round SS40 or 4" x 4" x 3/16" wall square steel tubing, grade 500. Gate posts shall be galvanized or coated and supported in concrete footings as specified by the design team.
- 2.03 FINISH:**
- A. Gate to be mill finish aluminum or color coated with polyester powder as specified. If powder coated, the gate (including track member) and all accessories shall be pretreated chemically by sand blasting or other acceptable method to ensure proper coating adherence.
- 2.04 WARRANTY:**
- A. The track assembly shall be warranted against manufacturing defects by the manufacturer for a period of (5) five years from date of sale.
- PART 3 - EXECUTION:**
- 3.01** Final grades and installation conditions shall be examined. Installation shall not begin until all unsatisfactory conditions are corrected.
- 3.02 INSTALLATION:**
- A. Equipment in this section shall be installed in strict accordance with the company's printed instructions unless otherwise shown on the contract drawings.
 - B. The gate and installation shall conform to ASTM F 1184 standards for aluminum cantilever slide gates, Type II, Class 2. See 1.02 C.
 - C. If the gate system is to be automated, the gate and installation shall also comply with ASTM F 2200 and UL 325. See 1.02 A and 1.02 B.
- 3.03 SYSTEM VALIDATION:**
- A. The complete system shall be adjusted to assure it is performing properly.
 - B. The system shall be operated for a sufficient period of time to determine that the system is in proper working order.
 - C. For operated gate systems - test and explain safety features:
 1. Each system feature and device is a separate component of the gate system.
 2. Read and follow all instructions for each component.
 3. Ensure that all instructions for mechanical components, safety devices and the gate operator are available for everyone who will be using the gate system.
 4. The warning signs shipped with the gate operator must be installed in prominent position on both sides of the gate.
 5. Ensure the owner is clear with regard to the safety points concerning the basic operational guidelines of the safety features of the gate operator system. These safety

REV	DESCRIPTION	DATE

CHAIN LINK ALUMINUM BOX FRAME 8'

FINISH TO BE DETERMINED

PALMSHIELD PROJECT # 32-GBC-15A4	CLIENT RETURN BY DATE
SCALE: N.T.S.	DATE: REV: BC0801