



Company Information

PalmSHIELD

12330 Cary Circle

La Vista, NE 68128

For over fifty years, we have been designing, engineering and installing industrial equipment screen walls, industrial louvered screen, mechanical equipment enclosures and architectural screening systems. In addition to our custom louvered screen wall fabrication division, PalmSHIELD fabricates square welded and woven wire mesh screen, grating, and perforated metal screen. You can find our work from the base of the Grand Canyon to the midst of the Yellowstone Forest. PalmSHIELD is the ultimate architectural equipment screening.

Our fabrication division operates in a ninety thousand square foot facility that provides complete fabrication and coatings. Our team is led by a seasoned group of certified welders, coaters, project engineers and drafters. All we do is custom fabricate architectural products. Perforated metal, square woven and weld mesh, grating, industrial louvers and welded wire mesh screens are some of our top products.



We have installed other manufacturer's louvered, perforated metal and square mesh screen systems over the years. Our experience with these systems was not satisfactory. Our systems are designed to

overcome all of our challenges in delivery, installation and sustainability. Having installed hundreds of screen wall systems and thousands of gates, we know a few things about what works and what does not.



What sets PalmSHIELD above all others is its fully framed manufactured panels and ease of installation. This rigid and robust frame protects the louvers, perforated metals, grating, cable railing and welded wire mesh during shipping, installation and for years to come. No assembly required. Our gates are manufactured first as standalone gates. We then fit our PalmSHIELD infill panels.

Our system is designed with the installers in mind. All of our panels and posts are factory aligned, then drilled and punched. All of our hardware is factory installed, removed and packaged. We factory install all the cabling for our cable railing. We are often not only the manufacturer but the installers as well. Our direct line of communication with the field gives us constant feedback and motivation to get it right.

PalmSHIELD has designed its own line of industrial hinges: the Gorilla Hinge. This hinge uses a half inch thick plate to mount to both the gate and gate post. The Gorilla hinge has a slight offset on the hinge plates to allow the gate to slightly close past full close. This intended design quirk was incorporated because we realize that not everything happens exactly like you want it to in the field. Sometimes, the gate posts are set an eighth to a sixteenth of an inch out of square. This is not noticeable at the post but a typical hinge would not allow the gate to come to a full close if the gate post was not set perfectly square. We empathize with these field irregularities and believe it is our responsibility to find a solution to offer our customers some flexibility.



PalmSHIELD louvered screening, walls, perforated metals, welded wire mesh and grating systems are perfect for providing excellent ventilation while keeping items out of sight from others. Using the industries' only picture frame design, each panel is rigid enough to stand on its own. Maintaining a consistent design throughout the system, PalmSHIELD can be configured as a series of screens, grills, swing gates and even sliding gates.

PalmSHIELD is custom fabricated to each application, allowing end users to select the amount of visibility and air flow by varying louver spacing or degree of perforation. Louvers may be placed vertically, horizontally or even diagonally



SAMPSON Aluminum

Swing Gate Product Data

PalmSHIELD SAMPSON Gate collection provides a permanent, upscale architectural gate for any commercial or industrial application. If you are looking for a proven engineered gate solution for dumpsters, trash enclosures and outdoor storage areas, the Sampson is an excellent and affordable solution. The SAMPSON gate collection incorporates an extruded tubular aluminum framework that encapsulates the wide variety of infill options. Our aluminum framework is a U-shape, providing a full finished edge on all four sides of the gate infill materials. This is an architectural gate solution when aesthetics matter. PalmSHIELD commercial gates are available in a wide variety of infill options including composite wood, vinyl, aluminum and louvers. When architecture matters, our planks may be placed in a modern horizontal or traditional vertical pattern. Unlike any other commercial and industrial gate manufacture, SAMPSON commercial gates are sweep blasted and powder coated. We offer an endless number of colors.

PalmSHIELD gates are custom designed and engineered to your commercial and industrial openings. We apply a series of engineering principles, accounting for the effects of the cantilevered load and wind load. No need to worry about future failed or sagging gates with our fully welded tubular framework and cable truss design on larger gates. PalmSHIELD has successfully built thousands of gates over the last thirty years.

PalmSHIELD understands commercial and industrial gates rely on the little things for continued operation. PalmSHIELD incorporates their own custom designed Gorilla hinges. These are not your ordinary hinges. Our industrial gate hinges utilize half inch thick bearing plates attached to a

two inch wide stainless steel barrel. Our commercial gates are too good for unsightly padlocks and wearing slide bolts. Only PalmSHIELD offers an internal commercial locking system with our Locinox re-keyable stainless steel and brushed aluminum locks. To hold our gates in-place, PalmSHIELD incorporates a one-inch schedule forty and padlock-able drop pin on every commercial and industrial gate leaf.

The solid aluminum screening incorporates a very modern tubular design. The aluminum tongue and groove planks set horizontally or vertically to match your facilities' exterior finishes. The tongue and groove planks are very attractive with chamfered corners and middle structural indentation.



SAMPSON Semi-Private Aluminum Commercial Swing Gate Materials Technical Data

PalmSHIELD complies to the following standards:

- A. ASTM B 209 – Standard Specification for Aluminum and Aluminum-Alloy Sheet and Plate.
- B. ASTM B 221 – Standard Specification for Aluminum and Aluminum-Alloy Extruded Bars, Rods, Wire, Profiles and Tubes.
- C. ASTM D3363 – Standard Test Method for Film Hardness by Pencil Test.
- D. ASTM D2794 – Standard Test Method for Resistance of Organic Coatings to the Effects of Rapid Deformation.
- E. ASTM B117 – Standard Practice for Operating Salt Spray Apparatus.
- F. ASTM D822 – Standard Practice for Filtered Open- Flame Carbon-Arc Exposures of Paint and Related Coatings.
- G. AWS D1.2 Structural Welding Code H. Aluminum. Extruded Aluminum

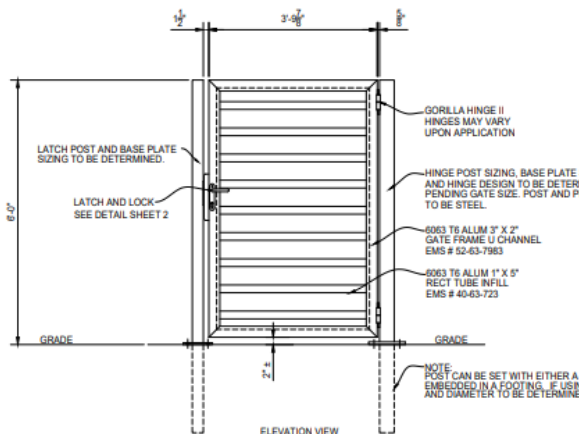

SINGLE SWING GATE ASSEMBLY
HINGE SIDE AND OPENING DIRECTION MAY VARY
SEE DETAIL SHEET 2 FOR HINGE AND LATCH

PalmSHIELD incorporates the following materials and design characteristics into our SAMPSON Solid Aluminum Gate:

Gate Panel Infill Description:

1. Gate Height: Varies
2. Gate Width: Varies; Widths over 12', verify with manufacturer
3. Gate panels consisting of horizontal planks fabricated with extruded aluminum framing structural profiles and supports by extruded aluminum fence posts.
4. Infill. 6" x 1" tubular slat tongue and groove slat, T-6063 as shown on plans and based on screen height

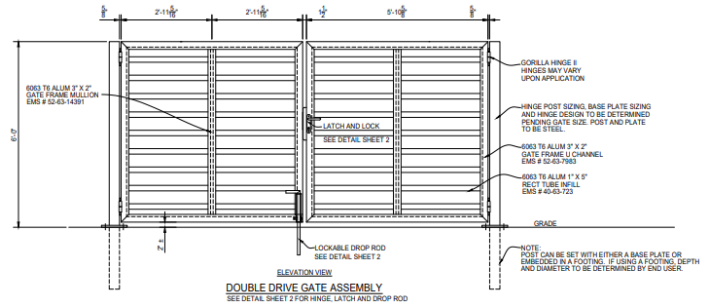

Gate Frame Description:

1. Gate shall have welded frame fabricated from extruded aluminum tubing with aluminum panels to match fencing material. Frame configurations shall be as indicated on the contract drawings
2. Welded frame, 2" x 3" U-Shaped extruded tubular T-6063 aluminum with infill to match fence infill

Gate Posts:

1. Gate panel post selection as shown on the plans and per manufacturer's selection.
2. Gate posts may be T-6063 aluminum or A-500 tubular steel as per manufacturer
3. Gate posts will be capped.

Anchor Bolts: Anchor bolts shall be adequate to support loads based on screening height, exposures and loading.

Gates Hardware:

1. All fittings and accessories shall be stainless steel and sized as specified by the fence manufacturer.

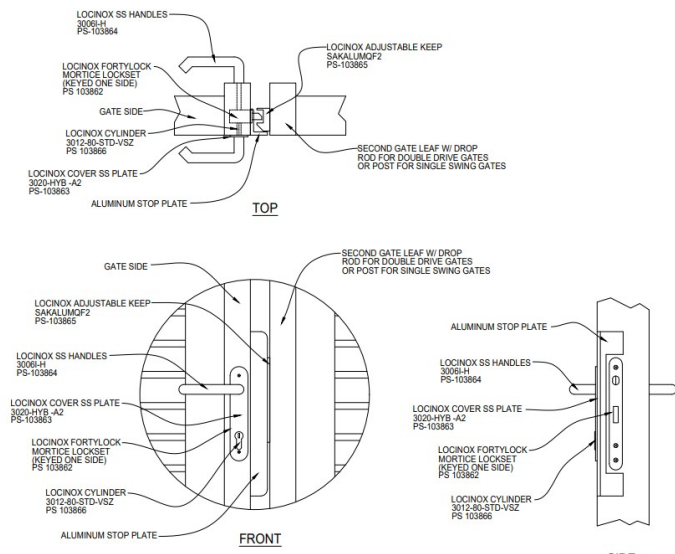

2. Gate hinges to be Gorilla barrel hinge with 3/4" rod, ball bearing, and grease zert. Hinge plate to be 1/2" thick plates offset to create a 5/8" gap. Standard hardware as required by the gate manufacturer for complete functional operation. Hinges to be bolted to gate frame and field welded to steel gate posts.
3. Gate lock to be Locinox FortyLock mortise lock. Lock to be industrial and polished 100% stainless steel locksets include a keyable cylinder and auto-latching mechanism. Lock to be internal lock with exterior grab handles. Lock may be keyed and rekeyed. Lock is accessible from both sides of gate.

4. Drop rods to be 1" schedule 40 pipe and through bolted to gate frame.
5. Hardware: Size and type as determined by the manufacturer. Provide two hinges per leaf.
6. Gate posts shall be as determined by manufacture. Gate posts to be specified to support gates.

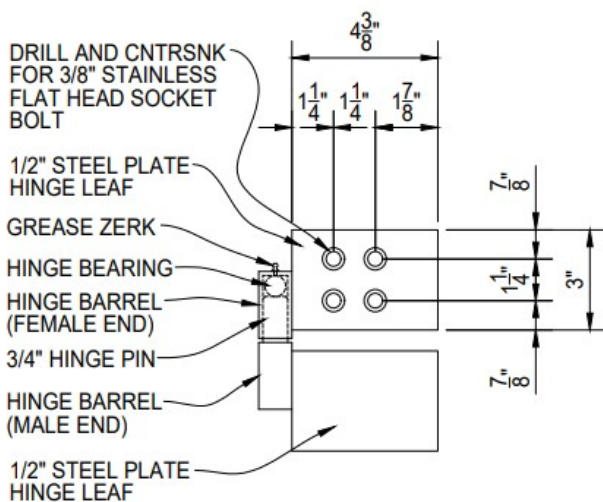
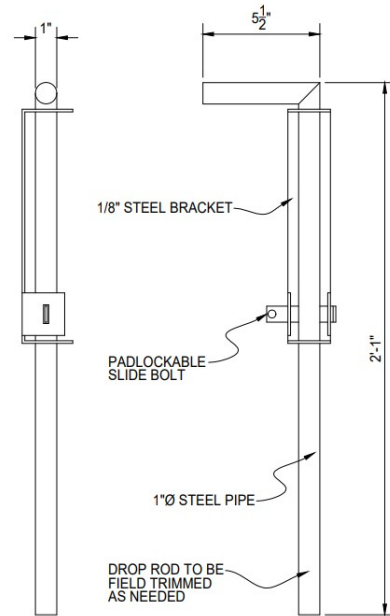

SIDE



SAMPSON Semi-Private Aluminum Commercial Swing Gate Installation Standards Technical Data

PalmSHIELD prides ourselves on having a reputation of being the most user-friendly architectural commercial gate manufacturer. We have been working directly with installers for over a decade to improve our gate installation process. At the onset of your commercial gate installation, you can look forward to:

- Our hinges are pre-mounted to the gate frames. The remaining half is packaged to be field welded to the steel gate post. You may request that we fully install your hinges if you are sure of site conditions.
- Our drop rods are all pre-mounted to the gate frames.
- Our internal locking devices are all pre-installed on the gate frames.
- If requested, our panic hardware and gate closures will be pre-mounted.
- You will receive a gate layout drawing that shows the installed gate elevation view.

Commercial Gate Important items to review at the start of the installation

- Every PalmSHIELD commercial gate is based on a drawing. This drawing is the basis for your installation. Please follow this drawing.
- Unless stated otherwise on your fabrication drawing, PalmSHIELD systems are to be installed level. As most systems are installed outdoors, most exterior paving is not level. If your surface is not level, you will need to verify and plan accordingly.
- Review the swing of your gate. Will it interfere with any other surface like raised equipment pads and curbing?

Commercial Gate Hardware included with your PalmSHIELD system

1. Ball bearing. These are packaged separately. One ball bearing per hinge.
2. Drop rods. These are pre-installed on the gates.
3. Locking devices. These are pre-installed on the gates.
4. Hinges. Half of the hinge is pre-installed on the gate post. The other half is packaged to be field welded unless instructed otherwise.
5. Oil. This oil is to be placed on the tip of each sheet metal screw.

Commercial Gate Hardware not included.

- Post anchors are not included. Based on 4000 psi concrete, you may consider 5/8" x 6" epoxy anchors or 5/8" x 5 1/2" wedge anchors. PalmSHIELD is not responsible for determining anchor type or installations. This should be determined by qualified individual based on site conditions.
- Padlocks for locking devices.

Commercial Gate Pre-installation Preparation

1. Using some form of marking chalk or tape, layout your gate in accordance with your included fabrication drawings. If you do not have these drawings, please inquire with PalmSHIELD for a copy.
2. Layout each post based on the inside to inside of gate opening dimensions stated on the drawing.
3. Mark-out the full swing of the gate in the full closed to full open position.
4. Verify the swinging gate does not impact other objects or interfere with access requirements.
5. If concerned about changing elevations, identify the highest elevation impacted by the full swing of your gate against the gate post spot elevation.
6. Verify if the change in this elevation is greater than the gap shown on the drawing from the bottom of the gate to top of surface.
7. If greater, the gate will bottom-out before fully opening.
8. Regardless if the gate bottoms-out or not, you may want to raise the gate to maintain the gap.
9. If a double drive, you will have to raise both gates equally so the locking mechanism still aligns.
10. If a single swing, you will have to raise the latch post equally so the locking mechanism still aligns.
11. Verify your commercial gate panels and gate posts compared to your fabrication drawings to assure every panel and posts was accurately fabricated. If you identify an error, please contact us as soon as possible and prior to any installation. PalmSHIELD will be responsible for fabrication errors but not installation costs as a result of these errors.

Commercial Gate Installation Steps

1. Using the gate post base plate template provided with your order,
 - a. Use the template to align the gate post to your site markings.
 - b. Make sure the gate post base plate runs parallel to the gate in the closed position. In other words, it is not twisted.
 - c. Mark the center of the anchor holes for gate posts.
2. Set your anchors.
3. Set your gate posts. Make sure your post is plumb in all directions.
4. Once you have determined the elevation of your gate, align the remaining half of the bottom gate hinge to the post. Align the gate hinge so the back of the barrel where it meets the plate is 3/8" in front of the post. In other words, there is a 3/8" gap between the barrel and the gate post.
5. Grind away any coatings that will interfere with welding the gate posts and hinges.
6. Clamp your hinge to the post. Make sure the hinge is plumb.
7. Clean and touch-up the welds with the included matching touch-up paint.
8. Hang the gate on the bottom hinge.

9. Block the gate in the closed position so that it is level and true. Mark the location of the top hinge and attach accordingly.
10. Make sure your gate does not interfere with any site conditions.
11. Close the gate to the appropriate closed location. Lower the drop rod and mark the socket location. Repeat for the open position if necessary. For drop rod sockets, we recommend a 1 ½" hammer drill or core bit. You may have to trim the drop rod.
12. The internal locking device should not require any further installation. The keys are located in the hardware package.
13. PalmSHIELD includes touch-up paint. Closely inspect your installation for any chips or scratches. Hold the can 6" to 8" from the area to be painted and sweep across it until entirely covered. The paint will blend with the powder coated surface.

Commercial Gate Tools Needed.

- At least six bar clamps with minimum of six inch jaw.
- Socket set

- Set of open end wrenches • 1" universal joint (knuckled socket).
- Screw gun with clutch adjustment.
- Hammer drill bits for anchors. To be determined by contractor. • 1 ½" hammer drill or core bit for drop rods (if required).
- Hammer drill bits.
- Level • Marking tape or paint
- String line.
- Rubber mallet
- Welder (if required for gate installations on steel posts)



SAMPSON Semi-Private Aluminum Commercial Swing Gate Coating Standards Technical Data

PROCESS

PalmSHIELD powder coating process and standards are based on a three-step process.

Step 1. Removal of oil, dirt, lubrication greases, metal oxides, welding scale etc. is essential prior to the powder coating process. PalmSHIELD utilizes both phosphates spray application and sweep blasting the surface. The use of a phosphate spray consist of degreasing, etching, de-smutting, various rinses and the final phosphating of the substrate The pre-treatment process both cleans and improves bonding of the powder to the metal. Blast media and blasting abrasives are used to provide surface texturing and preparation, etching, finishing, and degreasing.

Step 2. Applying the powder. The most common way of applying the powder coating to metal objects is to spray the powder using an electrostatic gun. The gun imparts a negative charge to the powder, which is then sprayed towards the grounded object by mechanical or compressed air spraying and then accelerated toward the workpiece by the powerful electrostatic charge.

Step 3. Curing the powder. When a thermosetting powder is exposed to elevated temperature, it begins to melt, flows out, and then chemically reacts to form a higher molecular weight [polymer](#) in a network-like structure.

STANDARDS

PalmSHIELD meets and exceeds the following standards for applying our factory finish to aluminum fence panels, posts and gates to receive a polyester powder coating.

Polyester powder coating: Electrostatically applied colored polyester powder coating heat cured to chemically bond finish to metal substrate.

Minimum hardness measured in accordance with ASTM D3363 2H.

Direct impact resistance tested in accordance with ASTM D2794. Withstand 160 inch-pounds.

Salt spray resistance tested in accordance with ASTM B117: No undercutting, rusting, or blistering after 500 hours in 5 percent salt spray at 95° F and 95% relative humidity after 1,000 hours, less than 3/16 inches undercutting.

Weatherability tested in accordance with ASTM D822: No film failure and 88 percent gloss retention after 1 year exposure in South Florida with test panels tilted 45°.

PRODUCT

PalmSHIELD uses only the highest quality products. Using PPG, Peridium TGIC Polyester powder coatings offering excellent application and performance characteristics. Peridium's tightly controlled particle size distribution provides extremely good first pass transfer efficiencies and edge coverage along with the smoothest film available. Long term exterior durability, high performance mechanical properties and overbake resistance are also common characteristics of these premium TGIC polyester coating

Cured Film Properties:

PCI Powder Smoothness Rating 8-9 (high gloss)
Specific Gravity (ASTM D792) 1.2 to 1.8 Adhesion (ASTM D3359) 5B (100%)
Gloss (ASTM D523) 30-99
Pencil Hardness (ASTM D3363) H-4H Impact (ASTM D2794) 160 - 240+ inch lbs.
Flexibility (ASTM D522) 1/8 inch - No fracturing
Humidity (ASTM D2247) 1,000+ hours Salt Spray (ASTM B117) 1,000+ hours



SAMPSON Semi-Private Aluminum Commercial Swing Gate Continued Product Care Technical Data

PalmSHIELD SAMPSON Solid Aluminum Gates should not further maintenance and care beyond customers best intentions to clean the product.

In the event you do wish to wash the product, we recommend using a high quality car wash soap or nonabrasive dish wash soap.

Using a nonabrasive wash mitt or sponge, gently scrub the product back and forth to remove any dust or debris. Once finished, gently hose off the remaining soap.

Do not use a power washer, abrasive tools, or scrapers.