



Company Information

PalmSHIELD

12330 Cary Circle

La Vista, NE 68128

For over fifty years, we have been designing, engineering and installing industrial equipment screen walls, industrial louvered screen, mechanical equipment enclosures and architectural screening systems. In addition to our custom louvered screen wall fabrication division, PalmSHIELD fabricates square welded and woven wire mesh screen, grating, and perforated metal screen. You can find our work from the base of the Grand Canyon to the midst of the Yellowstone Forest. PalmSHIELD is the ultimate architectural equipment screening.

Our fabrication division operates in a ninety thousand square foot facility that provides complete fabrication and coatings. Our team is led by a seasoned group of certified welders, coaters, project engineers and drafters. All we do is custom fabricate architectural products. Perforated metal, square woven and weld mesh, grating, industrial louvers and welded wire mesh screens are some of our top products.

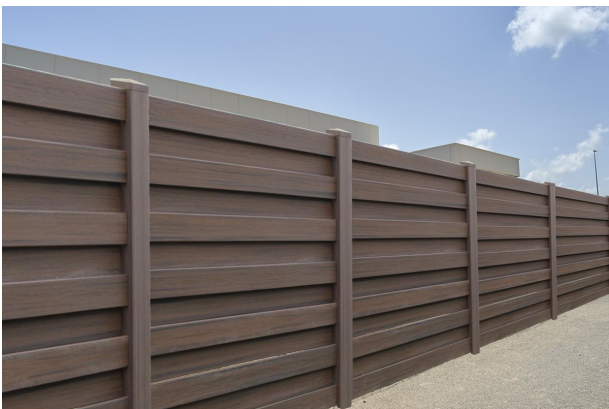

We have installed other manufacturer's louvered, perforated metal and square mesh screen systems over the years. Our experience with these systems was not satisfactory. Our systems are designed to overcome all of our challenges in delivery, installation and sustainability. Having installed hundreds of screen wall systems and thousands of gates, we know a few things about what works and what does not.



PalmSHIELD louvered screening is the industry leader in providing maximum air flow while still providing 100% direct visual screening. PalmSHIELD is the only louvered architectural screening manufacturer providing a structural picture frame design to fully enclose each panel for your rooftop screen or mechanical equipment screen. This allows our louvered panels great flexibility in spanning considerable widths and heights.

PalmSHIELD louver's aesthetic appeal is its contemporary and modern finish. Our panel and column combination is sleek and robust. PalmSHIELD louvers can be configured as a series of screens, grills, swing gates and even sliding gates. PalmSHIELD louvers is custom fabricated to each application, allowing end users to select, column locations, varied panel heights and widths and custom applications.

PalmSHIELD may be installed as a wall louver, ground or rooftop screen. PalmSHIELD louvers has its own independent structure that classifies it as a standalone louvered equipment screen system. It's this independent structure that carries the load of assuring the overall system meets the latest IBC and UBC codes.



Mercury Economic

Staggered Aluminum Posts & Vinyl Infill

PalmSHIELD's Mercury Staggered architectural screening series combines alternating aluminum, vinyl and composite planks placed horizontally between aluminum and vinyl posts. This shadow box architectural screening design is field installed and provides for flexibility.

PalmSHIELD uses exclusively the Woodland composite series vinyl based planks. These planks are available in a wide range of colors. The composite vinyl based planks are a well-balanced contrasting look of architectural woods and a more modern metal framework. The dark wood tones stand-up well up against aluminum framework. 6" wide composite vinyl based planks are field installed, allowing for flexibility in where you place your columns. All of our composite series planks require no painting, staining or sanding. These planks are stain and mold resistant while retaining the color in the sun.

The Mercury Staggered all aluminum screening incorporates our aluminum column series and horizontal aluminum planks for a very modern design. The Mercury Staggered screening is available in 6" wide planks. The air space in between the planks may vary based on your design.

PalmSHIELD uses exclusively the Ply Gem Woodland Select planks. Ply Gem's history using only the highest grade resins and industry best extruding process makes Ply Gem Woodland Select the best vinyl profiles in the industry. The planks are a 6" wide in a wide variety of colors and textures. From Chestnut Brown to Weathered Cedar, the planks contrast well with the powder coated aluminum or vinyl columns.

PalmSHIELD is the nation's largest architectural screening and louvered screening manufacturer.



All of PalmSHIELD's architectural screening products are fully shop fabricated, assembled, disassembled and packaged to assure all components fully align in the field. Mercury economic staggered is no exception to this standard of quality and customer service. All of our gate hardware is fully assembled and installed prior to shipping.

Material: Aluminum posts. Vinyl planks
Post dimensions: 4" x 4" x 1/8" aluminum
Plank dimensions: 1" x 6" vinyl
Installed plank profile: 1" x 5 1/2"
Plank spacing: 5 1/2" o.c.
Visibility: 100% direct visual screening
Structure: Routed posts and horizontal planks
Panel width: Standard is 48" to 60".
Panel height: Standard is up to 72"



Mercury Economic Staggered Aluminum Posts & Vinyl Infill

Technical Data

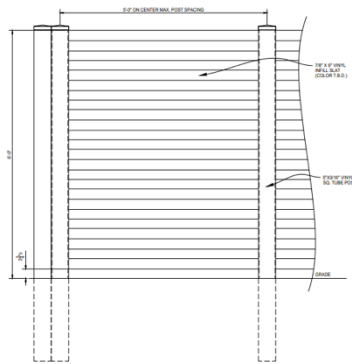

TYPICAL PANEL ELEVATION

PalmSHIELD complies to the following standards:

- A. ASTM B 209 – Standard Specification for Aluminum and Aluminum-Alloy Sheet and Plate.
- B. ASTM B 221 – Standard Specification for Aluminum and Aluminum-Alloy Extruded Bars, Rods, Wire, Profiles and Tubes.
- C. ASTM D3363 – Standard Test Method for Film Hardness by Pencil Test.
- D. ASTM D2794 – Standard Test Method for Resistance of Organic Coatings to the Effects of Rapid Deformation.
- E. ASTM B117 – Standard Practice for Operating Salt Spray Apparatus.
- F. ASTM D822 – Standard Practice for Filtered Open-Flame Carbon-Arc Exposures of Paint and Related Coatings.
- G. AWS D1.2 Structural Welding Code – Aluminum. ASTM D-7032-04: Standard Specification for Establishing Performance Ratings.

- H. ASTM D256 Standard Test Methods for Determining the Izod Pendulum Impact Resistance of Plastics.
- I. ASTM D638 Standard Test Method for Tensile Properties of Plastics.
- J. ASTM D648 Standard Test Method for Deflection Temperature of Plastics Under Flexural Load in the Edgewise Position.
- K. ASTM D792 Standard Test Methods for Density and Specific Gravity (Relative Density) of Plastics by Displacement.
- L. ASTM D790 Standard Test Methods for Flexural Properties of Unreinforced and Reinforced Plastics and Electrical Insulating Materials.
- M. ASTM D4216 Standard Specification for Rigid Poly (Vinyl Chloride) (PVC) and Related PVC and Chlorinated Poly (Vinyl Chloride) (CPVC) Building Products Compounds.
- N. ASTM F964 Standard Specification for Rigid Poly (Vinyl Chloride) (PVC) Exterior Profiles Used for Fencing.

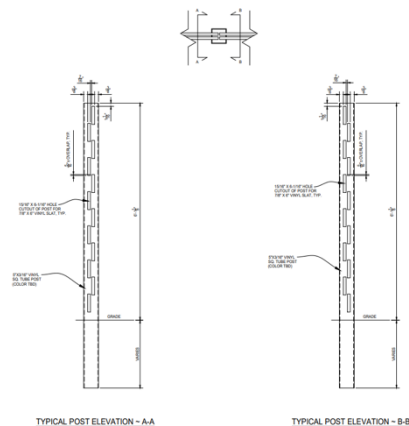

TYPICAL POST ELEVATION - A-A

TYPICAL POST ELEVATION - B-B

Description:

1. Panel Height: Varies
2. Panel Width: Not to exceed 60" o.c.
3. Staggered plank system consisting of horizontal supported by extruded aluminum fence posts.
4. Infill: 7/8" x 6" (22.2 x 152 mm) polyvinyl chloride tubular coextrusion plank. PlyGem Woodland Select Series tubular planks per manufacturers standard colors.

- i. Planks to be held into posts with spring clips provided.
- ii. Planks be installed plumb alternating 1 1/2" horizontal offset and 1/2" vertical overlap.
- 7. Planks to be fabricated to provide a raised notch on each end that allows plank to slide into the post but not easily slide out

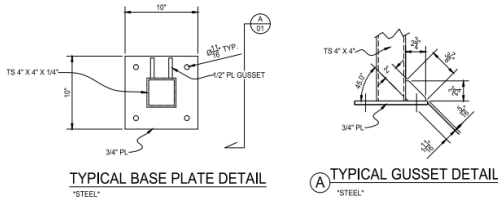

Fence Posts:

1. Panel posts shall be 4" square x 1/8" inch minimum extruded tubular aluminum sections with solid aluminum caps. Length as specified on the contract drawings.
2. Posts to be routed to receive planks.
3. On center post spacing shall be as specified by manufacturer but not to exceed 60" o.c.
4. All fence posts to be plated with 8" x 8" x 5/8" aluminum plates with four 3/4" hole for anchors. OR extended 24" into footing as shown.

Fittings and accessories: All fittings and accessories shall be stainless steel and sized as specified by the fence manufacturer. Fence panels to be attached to posts with 1/4" x 1" stainless steel screws. Panels and posts are predrilled to support level installation.

Anchor Bolts: Anchor bolts shall be adequate to support loads based on screening height, exposures and loading.

Gates: Swing to exterior of enclosure, size as shown on contract drawings.

1. Panel spacing, style and appearance shall be identical to fence panels.
2. Gate hinges to be Gorilla barrel hinge with 3/4" rod, ball bearing, and grease zert. Hinge plate to be 1/2" thick plates offset to create a

5/8" gap. Standard hardware as required by the gate manufacturer for complete functional operation. Hinges to be bolted to gate frame and field welded to steel gate posts.

3. Gate latch to be internal lock with exterior grab handles. Lock may be keyed and rekeyed. Lock is accessible from both sides of gate.

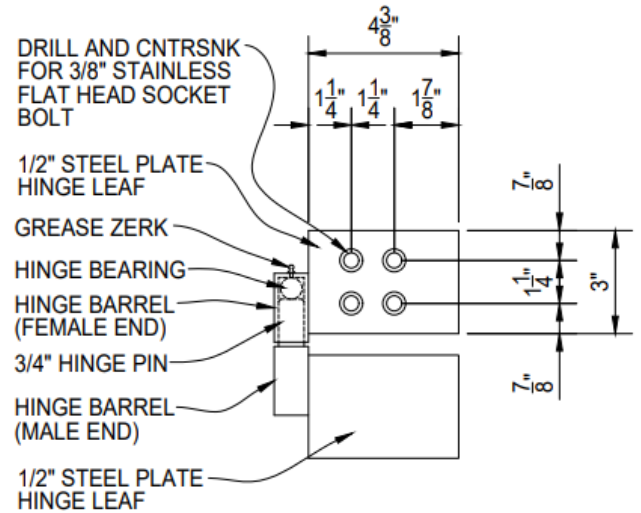

SIDE

4. Welded frame, 4" x 4" x 1/8" vertical uprights and 2" x 2" x 1/8" horizontal extruded tubular T-6063 aluminum with infill to match fence infill.
5. Drop rods to be 1" schedule 40 pipe and through bolted to gate frame.

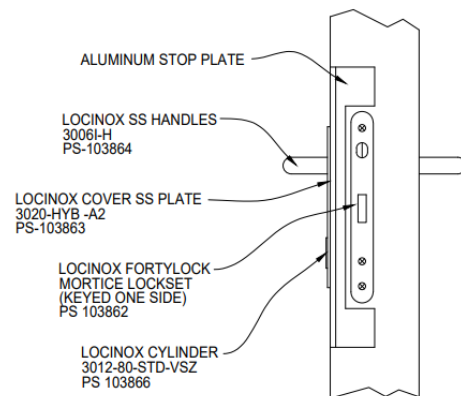

SIDE

6. Hardware: Size and type as determined by the manufacturer. Provide two hinges per leaf.

- a. Provide 1 inch diameter center cane bolt assembly and strike, each door.
7. Gate shall have welded frame fabricated from extruded aluminum tubing with aluminum panels to match fencing material. Frame configurations shall be as indicated on the contract drawings.

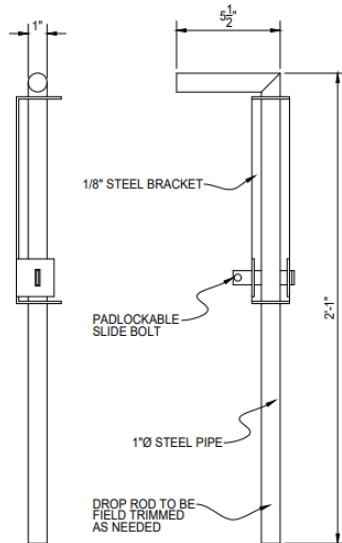

DROP ROD DETAIL

8. Gate posts shall be as determined by manufacture. Gate posts to be specified to support gates.



Mercury economic staggered aluminum posts & vinyl infill Coating

Standards Technical Data

PROCESS

PalmSHIELD powder coating process and standards are based on a three-step process.

Step 1. Removal of oil, dirt, lubrication greases, metal oxides, welding scale etc. is essential prior to the powder coating process. PalmSHIELD utilizes both phosphates spray application and sweep blasting the surface. The use of a phosphate spray consist of degreasing, etching, de-smutting, various rinses and the final phosphating of the substrate. The pre-treatment process both cleans and improves bonding of the powder to the metal. Blast media and blasting abrasives are used to provide surface texturing and preparation, etching, finishing, and degreasing.

Step 2. Applying the powder. The most common way of applying the powder coating to metal objects is to spray the powder using an electrostatic gun. The gun imparts a negative charge to the powder, which is then sprayed towards the grounded object by mechanical or compressed air spraying and then accelerated toward the workpiece by the powerful electrostatic charge.

Step 3. Curing the powder. When a thermosetting powder is exposed to elevated temperature, it begins to melt, flows out, and then chemically reacts to form a higher

Cured Film Properties:

PCI Powder Smoothness Rating 8-9 (high gloss)
Specific Gravity (ASTM D792) 1.2 to 1.8
Adhesion (ASTM D3359) 5B (100%)
Gloss (ASTM D523) 30-99
Pencil Hardness (ASTM D3363) H-4H
Impact (ASTM D2794) 160 - 240+ inch lbs.
Flexibility (ASTM D522) 1/8 inch - No fracturing
Humidity (ASTM D2247) 1,000+ hours
Salt Spray (ASTM B117) 1,000+ hour

molecular weight [polymer](#) in a network-like structure.

STANDARDS

PalmSHIELD meets and exceeds the following standards for applying our factory finish to aluminum fence panels, posts and gates to receive a polyester powder coating.

Polyester powder coating: Electrostatically applied colored polyester powder coating heat cured to chemically bond finish to metal substrate.

Minimum hardness measured in accordance with ASTM D3363 2H.

Direct impact resistance tested in accordance with ASTM D2794. Withstand 160 inch-pounds.

Salt spray resistance tested in accordance with ASTM B117: No undercutting, rusting, or blistering after 500 hours in 5 percent saltspray at 95° F and 95% relative humidity after 1,000 hours, less than 3/16 inches undercutting.

Weatherability tested in accordance with ASTM D822: No film failure and 88 percent gloss retention after 1 year exposure in South Florida with test panels tilted 45°.

PRODUCT

PalmSHIELD uses only the highest quality products. Using PPG, Peridium TGIC Polyester powder coatings offering excellent application and performance characteristics. Peridium's tightly controlled particle size distribution provides extremely good first pass transfer efficiencies and edge coverage along with the smoothest film available. Long term exterior durability, high performance mechanical properties and overbake resistance are also common characteristics of these premium TGIC polyester coating



Mercury economic staggered aluminum posts & vinyl infill Installation Standards Technical Data

PalmSHIELD Mercury Series Installation

PalmSHIELD prides ourselves on having a reputation of being the most user-friendly architectural screen system to install. We have been working directly with installers for over a decade to improve our overall installation. At the onset of your installation, you can look forward to:

- All of our posts are pre-routed to receive the planks.
- Vinyl and aluminum planks will be pre-notched to slide directly into the posts. Composite planks will come with steel clips to be screwed to the ends of the planks.
- Our hinges are pre-mounted to the gate frames. The remaining half is packaged to be field welded to the steel gate post. You may request that we fully install your hinges if you are sure of site conditions.
- Our hinges are pre-mounted to the gate frames. The remaining half is packaged to be field welded to the steel gate post. You may request that we fully install your hinges if you are sure of site conditions.
- Our drop rods are all pre-mounted to the gate frames.
- Our internal locking devices are all pre-installed on the gate frames.
- You will receive a system layout drawing that provides the distance between posts so you may select the proper planks for each bay.
- You will receive a packing list that indicates the quantity and length of every plank and post.

Important items to review at the start of the installation

- Every PalmSHIELD installation was initiated with a fabrication drawing. This drawing is the basis for your installation. Please follow this drawing to the letter as there is little flexibility in the dimensions.
- Unless stated otherwise on your fabrication drawing, PalmSHIELD systems are to be installed level. As most systems are installed outdoors, most exterior paving is not level. If your surface is not level, you will need to verify and plan accordingly. The Mercury series does provide some flexibility for being installed on slopes. However, the end result may not be attractive as the planks slope from post to post.
- Review the swing of your gate. Will it interfere with any other surface like raised equipment pads and curbing?

Hardware included with your PalmSHIELD Mercury series

system

1. Metal clips and adjoining screws (composite planks only).



2. Ball bearing. These are packaged separately. One ball bearing per hinge.
3. Drop rods. These are pre-installed on the gates.
4. Locking devices. These are pre-installed on the gates.
5. Hinges. Half of the hinge is pre-installed on the gate post. The other half is packaged to be field welded unless instructed otherwise.
6. Oil. This oil is to be placed on the tip of each sheet metal screw



Sheet Metal Screw

Hardware not included.

- Post anchors are not included. Based on 4000 psi concrete, you may consider 5/8" x 6" epoxy anchors or 5/8" x 5 1/2" wedge anchors. PalmSHIELD is not responsible for determining anchor type or installations. This should be determined by qualified individual based on site conditions.
- Padlocks for locking devices.

Pre-installation Preparation

1. Using some form of marking chalk or tape, layout your system in accordance with your included fabrication drawings. If you do not have these drawings, please inquire with PalmSHIELD for a copy.
2. Layout each run from center to center of posts.
3. Layout gate openings from inside of post to inside of post.
4. Layout the entire system prior to starting to insure it fits your space as you intended.
5. If concerned about changing elevations, identify the highest elevation on your site where the system is to be installed. This may be your benchmark for setting your posts. All of your posts will have to be installed to this elevation. A couple hints to make this easy.
 - a. Start at the highest elevation and level each panel as you go. OR
 - b. Run a string line along the installation. Set it flush at the point of highest elevation and then

- level it over the balance of the installation. OR
 - c. Use a site level and determine the change in elevation at each post.
 - d. As the elevation drops, you will have to either shim under your posts or install leveling nuts to your anchors.
6. If changing elevations are not an issue, start your PalmSHIELD system at a permanent structure such as building or wall. It is to start here and work out into space where you do not have to be concerned about ending gaps.
 7. PalmSHIELD Mercury series will allow for some slope but the end result may not be agreeable in appearance.

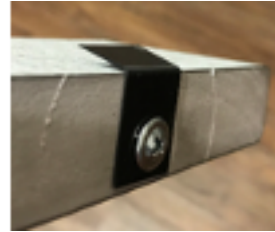

9. If you are installing vinyl or aluminum planks, the notch should be present on both ends. In some cases, you may have to raise the notch slightly to catch. You can do this with a flat screw driver.



10. Slide the planks into the post. Best to start on one end of the project and work your way through the installation.
11. The vinyl and aluminum planks will be notched. Make sure the notch is slide-in and through the wall of the post. Applying some effort, pull on the plank to assure it will not easily come-out of the post. If it does, refer to step 9 and repeat.
12. Install all the planks in the first bay, then move on to the next bay.

Installation Steps

1. Verify your planks and posts compared to your fabrication drawings to assure every plank and post was accurately fabricated. If you identify an error, please contact us as soon as possible and prior to any installation. PalmSHIELD will be responsible for fabrication errors but not installation costs as a result of these errors.
2. It is best to install your PalmSHIELD Mercury system by initially setting all your posts per the fabrication drawings.
3. If your posts are plated, using the post base plate template provided with your order,
 - a. use the template to align the first post to your site markings.
 - b. Make sure the post base plate runs parallel to the run and it is not twisted.
 - c. Mark the center of the anchor holes.
 - d. Set your anchors.
4. Select your first post based on the drawing. Posts are labeled in accordance with the drawing. You should verify if it is a corner, end, or gate post from the fabrication drawing. This can be identified based on the holes routed to receive the planks in the posts.
5. Set your first post. Make sure your post is plumb in all directions. Use this process to set all posts.
6. If you are setting your posts in a concrete footing.
 - a. Dig your holes in accordance with the fabrication drawings.
 - b. Mix and place your concrete in the hole(s).
 - c. Stab your posts so it aligns with your site markings or string line.
 - d. Make sure your post is parallel to the run and is not twisted.
 - e. Make sure your post is plumb and level.
 - f. Make sure all posts are set to the same elevation to provide for a level louver installation. This may be done with a level string line or with a site level.
7. Once your posts are set, layout your planks in accordance with the fabrication drawings. Your planks will typically be 3" longer than the inside to inside post dimension or 2" shorter than the center to center post dimension.
8. If you are installing composite planks, screw the clips to both ends of each plank. The clip should be centered on the plank and the screw should be placed into the end of the plank allowing the flared end of the clip to be adjacent to the side of the plank.

Gate Installation:

1. At gate opening, be sure to install gate posts as shown on the drawings. Be sure your openings (inside to inside of post) are accurate.
2. Gate installations will vary based on site conditions. You should consider the swing of the gate relative to the grade that it sweeps over and make sure that there is plenty of clearance. Look for steep rising slopes, adjoining equipment pads with a higher elevation and curbing.
3. Once you have determined the elevation of your gate, weld the remaining half of the gate hinge to the post. Align the gate hinge so the back of the barrel where it meets the plate is 3/8" in front of the post. In other words, there is a 3/8" gap between the barrel and the gate post.
4. Close the gate to the appropriate location. Lower the drop rod and mark the socket location. Repeat for the open position if necessary. For drop rod sockets, we recommend a 1 1/2" hammer drill or core bit. You may have to trim the drop rod.
5. The internal locking device should not require any further installation. The keys are located in the hardware package.
6. PalmSHIELD includes touch-up paint. Closely inspect your installation for any chips or scratches. Hold the can 6" to 8" from the area to be painted and sweep across it until entirely covered. The paint will blend with the powder coated surface.

Tools Needed.

- Socket set
- Set of open end wrenches
- Screw gun or electric drill
- Hammer drill bits for anchors. To be determined by contractor.

- 1 ½" hammer drill or core bit for drop rods (if required).
- Hammer drill bits.
- Level
- Marking tape or paint
- String line.
- Rubber mallet
- Welder (if required for gate installations on steel posts)



Mercury economic staggered aluminum posts & vinyl infill Technical Data

PalmSHIELD Mercury economic staggered should not further maintenance and care beyond customers best intentions to clean the product.

In the event you do wish to wash the product, we recommend using a high quality care wash soap or nonabrasive dish wash soap.

Using a nonabrasive wash mitt or sponge, gently scrub the product back and forth to remove any dust or debris. Once finished, gently hose off the remaining soap.

Do not use a power washer, abrasive tools, or scrapers.