



Company Information

PalmSHIELD

12330 Cary Circle
La Vista, NE 68128

For over fifty years, we have been designing, engineering and installing industrial equipment screen walls, industrial louvered screen, mechanical equipment enclosures and architectural screening systems. In addition to our custom louvered screen wall fabrication division, PalmSHIELD fabricates square welded and woven wire mesh screen, grating, and perforated metal screen. You can find our work from the base of the Grand Canyon to the midst of the Yellowstone Forest. PalmSHIELD is the ultimate architectural equipment screening.

Our fabrication division operates in a ninety thousand square foot facility that provides complete fabrication and coatings. Our team is led by a seasoned group of certified welders, coaters, project engineers and drafters. All we do is custom fabricate architectural products. Perforated metal, square woven and weld mesh, grating, industrial louvers and welded wire mesh screens are some of our top products.



We have installed other manufacturer's louvered, perforated metal and square mesh screen systems over the years. Our experience with these systems was not satisfactory. Our systems are designed to overcome all of our challenges in delivery, installation and sustainability. Having installed hundreds of screen wall systems and thousands of gates, we know a few things about what works and what does not.



What sets PalmSHIELD above all others is its fully framed manufactured panels and ease of installation. This rigid and robust frame protects the louvers, perforated metals, grating, cable railing and welded wire mesh during shipping, installation and for years to come. No assembly required. Our gates are manufactured first as standalone gates. We then fit our PalmSHIELD infill panels.

Our system is designed with the installers in mind. All of our panels and posts are factory aligned, then drilled and punched. All of our hardware is factory installed, removed and packaged. We factory install all the cabling for our cable railing. We are often not only the manufacturer but the installers as well. Our direct line of communication with the field gives us constant feedback and motivation to get it right.

PalmSHIELD has designed its own line of industrial hinges: the Gorilla Hinge. This hinge uses a half inch thick plate to mount to both the gate and gate post. The Gorilla hinge has a slight offset on the hinge plates to allow the gate to slightly close past full close. This intended design quirk was incorporated because we realize that not everything happens exactly like you want it to in the field. Sometimes, the gate posts are set an eighth to a sixteenth of an inch out of square. This is not noticeable at the post but a typical hinge would not allow the gate to come to a full close if the gate post was not set perfectly square. We empathize with these field irregularities and believe it is our responsibility to find a solution to offer our customers some flexibility.



PalmSHIELD louvered screening, walls, perforated metals, welded wire mesh and grating systems are perfect for providing excellent ventilation while keeping items out of sight from others. Using the industries' only picture frame design, each panel is rigid enough to stand on its own. Maintaining a consistent design throughout the system, PalmSHIELD can be configured as a series of screens, grills, swing gates and even sliding gates.

PalmSHIELD is custom fabricated to each application, allowing end users to select the amount of visibility and air flow by varying louver spacing or degree of perforation. Louvers may be placed vertically, horizontally or even diagonally



Tiger Solid Aluminum Slide Gate Product Data

PalmSHIELD Tiger slide gate series combines the appeal of PalmSHIELD's architectural screening options to a commercial cantilever slide gate. This is a uncanny pairing as cantilever slide gates are truly suspended and cantilevered through the opening, not utilizing any ground supports or wheels. This means that the structural design of the gate itself must be considerable, supporting both the weight of the architectural panels and the wind load created.

PalmSHIELD Tiger commercial and industrial slide gates provide a wide array of PalmSHIELD infill options including composite wood, vinyl, aluminum, louvers, perforated and wire mesh. The architectural infill panels are installed into the cantilever slide gate to provide continuity with adjoining screening. Unlike any other commercial slide gate manufacture, PalmSHIELD Tiger commercial slide gates are sweep blasted and powder coated. We offer an endless number of colors.

Unlike standard cantilever slide gates, the PalmSHIELD Tiger series incorporates a much

larger structural framework. The vertical framework begins with a 4" x 2" tubular outer framework encapsulating a 3" x 3" interior angle or 2" x 3" tubular U-shaped picture frame. This is an industrial and commercial gate design when aesthetics are critical. The Tiger series utilizes a upper single or double track design based on the weight and length of the opening. The bottom guide is no less than a 5" x 2" tubular member supporting the gate against wind load.

PalmSHIELD Tiger gates are each custom engineered to your tallest and widest openings. PalmSHIELD applies a series of engineering principles, accounting for the effects of the cantilevered load and wind load. PalmSHIELD has successfully built tens of thousands of industrial and commercial gates over the last thirty years.

The solid aluminum screening incorporates a very modern tubular design. The aluminum tongue and groove planks set horizontally or vertically to match your facilities' exterior finishes. The tongue and groove planks are very attractive with chamfered corners and middle structural indentation.



PalmSHIELD
Tiger Solid Aluminum Slide
Gate Materials Technical
Data

PalmSHIELD complies to the following standards:

- A. ASTM B 209 – Standard Specification for Aluminum and Aluminum-Alloy Sheet and Plate.
- B. ASTM B 221 – Standard Specification for Aluminum and Aluminum-Alloy Extruded Bars, Rods, Wire, Profiles and Tubes.
- C. ASTM D3363 – Standard Test Method for Film Hardness by Pencil Test.
- D. ASTM D2794 – Standard Test Method for Resistance of Organic Coatings to the Effects of Rapid Deformation.
- E. ASTM B117 – Standard Practice for Operating Salt Spray Apparatus.
- F. ASTM D822 – Standard Practice for Filtered Open-Flame Carbon-Arc Exposures of Paint and Related Coatings.
- G. FS RR-191/2D Type III & IV – Federal Specification for Cantilever Slide Gates
- H. ASTM F 1184-88 Standard Specification for Industrial and Commercial Horizontal Slide Gates
- I. ASTM F 2200 Standard Gate Construction

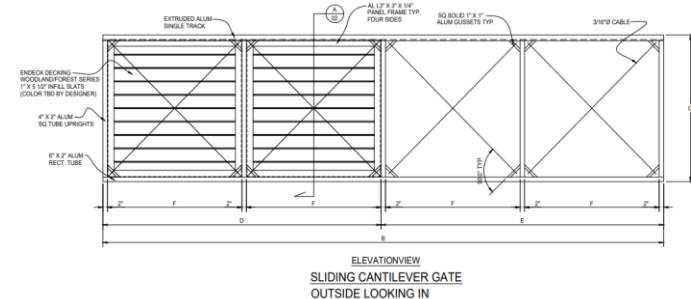

PalmSHIELD incorporates the following materials and design characteristics into our Tiger Solid Aluminum Slide Gate:

Gate Panel Infill Description:

1. Extruded Aluminum: ASTM B 221, Alloy 6063 – Temper T-6.
2. Sheet Aluminum: ASTM B211, Alloy 6063 – Temper T6.

3. Powder Coating Material Hardness: ASTM 3363 2H.

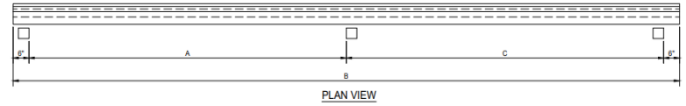

Gate Panel Description:

1. Panel Height: Varies
2. Louver Panel Width. Not to exceed 60”.
3. Infill. 6” x 1” tubular slat tongue and groove slat, T-6063 as shown on plans and based on screen height.
4. Vertical Framework: 3 inch x 3 inch x ¼ inch aluminum angle. Framework supporting the louvers shall be solid welded and mitered.
5. Horizontal Top Cap: 3 inch x 3 inch x ¼ inch aluminum top cap.
6. Horizontal Bottom Cap: 3 inch x 3 inch x ¼ inch angle bottom cap.
7. Cross Bar: 2 inch x 1/8 inch aluminum flat bar.
8. Fittings and accessories: All fittings and accessories shall be stainless steel and sized as specified by the fence manufacturer.

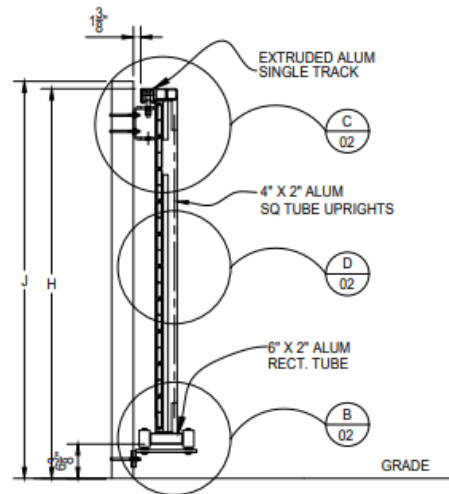

Gate: Cantilever Slide

1. Fully Fabricated Gate: The gate shall be fully shop fabricated in its largest possible sections. All gate frames, supports and tracks are to be joined by welded connections.
2. Materials: The frame(s) and track(s) are to be fabricated from aluminum extrusions (6063-T6).
3. Single track applications provide an upper track that weighs 5.15# / foot.
4. Double track applications provide an upper track that weighs 11.916# / ft.
5. The entire gate shall receive fully trussed. Trussing may be established by 3/16” galvanized cable in “X” pattern throughout the opening and tail section of the gate. All cable assemblies will be equipped with field adjustable tension devices. All trussing will be placed behind the

PalmSHIELD panels.

6. The vertical supports of the gate shall be 2" x 4" and shall not be spaced greater than six feet on center and will not exceed the height of the gate.
7. The bottom track shall be 2" x 4". For openings greater than 20' bottom rail shall be 5" x 2".
8. Once gate is fully fabricated and trussing is installed and tensioned, PalmSHIELD panels will be installed in-between vertical uprights. Panels will be welded in place.

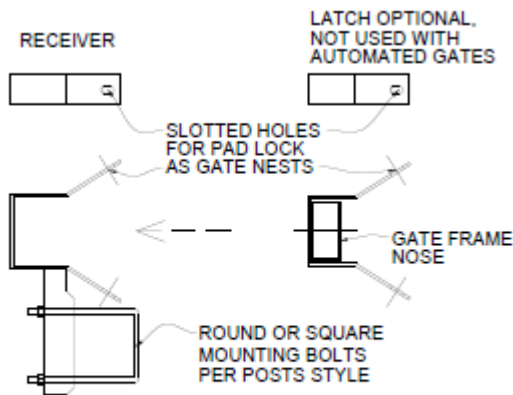

GATE RECEIVER DETAIL

Gates Hardware:

1. Gate truck assemblies shall be tested for continuous duty and shall have precision ground and hardened components. Bearings shall be pre-lubricated and contain shock resistant outer races and captured seals.
2. Gate truck assemblies shall be supported by a minimum 5/8" plated steel bolt with self-aligning capability, rated to support a 2,000 # reaction load.

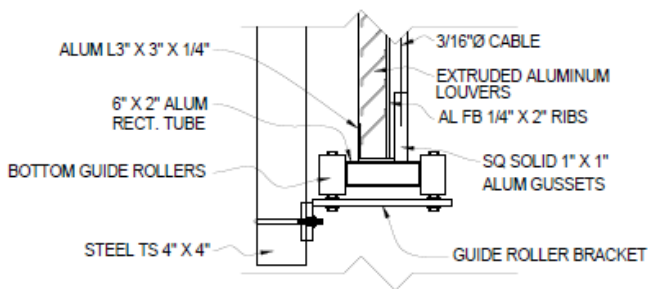

3. Hanger brackets shall be hot dipped galvanized steel with a minimum 3/8" thickness that is also gusseted for additional strength.
4. Gate top track and supporting hangar bracket assemblies shall be certified by a licensed professional engineer to withstand a 2,000 lb. vertical reaction load without exceeding allowable stresses.



Tiger Solid Aluminum

Slide Gates Installation

Standards Technical Data

PalmSHIELD prides ourselves on having a reputation of being the most user-friendly architectural commercial cantilever slide gate manufacturer. We have been working directly with installers for over a decade to improve our cantilever slide gate installation process.

Commercial slide gate important items to review at the start of the installation

- Every PalmSHIELD commercial cantilever slide gate is based on a drawing. This drawing is the basis for your installation. Please follow this drawing.
- Unless stated otherwise on your fabrication drawing, PalmSHIELD systems are to be installed level. As most systems are installed outdoors, most exterior paving is not level. If your surface is not level, you will need to verify and plan accordingly.
- Review the slide of your gate. Will it interfere with any other surface like raised equipment pads, change in elevation and curbing?

Commercial cantilever slide gate hardware included with your PalmSHIELD system

1. Truck assemblies. Depending on whether you gate is a double or single track system, you will receive two or four trucks respectively. These will slide in the gate track and mount to the upper track brackets.
2. Truck brackets. For each truck assembly, you will receive a truck bracket. Truck brackets are mounted to the gate post and the truck is mounted to the bracket.
3. Bottom guide rollers. You will receive two bottom guide rollers. The cantilever slide gate will slide between the rollers. The guide rollers are mounted to the gate posts.
4. Locking devices. Depending upon your design, you will receive a locking device pre-installed or packaged. The locking device mounts to the nose of the gate and the gate receiver post.

Commercial cantilever slide gate hardware not included.

- Post anchors are not included. Based on 4000 psi concrete, you may consider 5/8" x 6" epoxy anchors or 5/8" x 5 1/2" wedge anchors. PalmSHIELD is not responsible for determining anchor type or installations. This should be determined by qualified individual based on site conditions.
- Padlocks for locking devices.

Commercial cantilever slide gate pre-installation plan

1. Using some form of marking chalk or tape, layout your gate in accordance with your included fabrication drawings. If you do not have these drawings, please inquire with PalmSHIELD for a copy.
2. Layout each post based on the inside to inside of gate opening dimensions stated on the drawing.
3. Mark-out the full slide of the gate in the full closed to full open position.
4. Verify the slide gate does not impact other objects or interfere with access requirements.
5. If concerned about changing elevations, identify the highest elevation impacted by the full slide of your gate against the gate post spot elevation.
6. Verify if the change in this elevation is greater than the gap shown on the drawing from the bottom of the gate to top of surface.
7. If greater, the gate will bottom-out before fully opening or closing.
8. Regardless if the gate bottoms-out or not, you may want to raise the gate to maintain the gap.
9. If a double drive cantilever slide gate, you will have to raise both gates equally so the locking mechanism still aligns.
10. If a single cantilever slide gate, you will have to raise the latch post equally so the locking mechanism still aligns.
11. Verify your commercial slide gate and gate posts dimensions compared to your fabrication drawings to assure the gate and posts were accurately fabricated. If you identify an error, please contact us as soon as possible and prior to any installation. PalmSHIELD will be responsible for fabrication errors but not installation costs as a result of these errors.

Commercial cantilever slide gate installation steps

1. Using the gate post base plate template provided with your order,
 - a. Use the template to align the gate post to your site markings.
 - b. Make sure the gate post base plate runs parallel to the gate in the closed position. In other words, it is not twisted.
 - c. Mark the center of the anchor holes for gate posts.
2. Set your anchors.
3. Set your gate posts. Make sure your post is plumb in all directions.
4. Install the truck brackets on the gate posts per the fabrication drawings. The brackets are angle shaped. The horizontal leg of the angle is installed up. The bracket should be installed on the same side of the post where the gate is to be installed. The height of these brackets will determine the overall height of the gate. It is important that the brackets are installed level to one another. If not, the gate will slope and potentially roll under its own force, causing damage or harm to others.
5. Use a level to bridge the brackets to assure the brackets are installed level. If not, adjust accordingly.
6. Install the two bottom rollers. The rollers are to be installed up with the horizontal bracket toward the bottom as per your fabrication drawings. These should be installed loose initially to be adjusted later once the gate is installed.
7. Install the gate.
 - a. Remove the cantilever gate track rear stop bolt from the back of the gate. The stop

- bolts are located at the ends of the upper track. These are installed horizontally through the track. When in place, these prevent the gate from coming off the track.
- b. Position the cantilever gate so that the tail of the gate may be slid onto and down the first roller assembly.
 - c. To do this, you will need to position the tail of the gate aligned with the first roller closest to the opening. The cantilever gate will need to be parallel to the opening.
 - d. Lift the gate so that the roller is aligned to the track. Now, slide the cantilever gate onto the roller and then onto the next roller.
 - e. Re-install the gate track rear stop bolt.
 - f. Center the cantilever gate between the truck assemblies.
 - g. Place a level on the gate to be sure it is level. If not level, raise or lower one of the two truck bracket assemblies on the post.
 - h. At the same time, check the cantilever gate for height. It is typical for the top of the gate to be aligned with the top of the adjoining screening or fence. The cantilever gate will should have an approximate 5" gap from underside of gate to top of slab below.

- i. Once the gate is positioned for height and level. Roll the cantilever gate fully opened and closed to be sure it does not interfere with any adjoining surface or obstacle.
8. If everything is adjusted, install the latch assembly.
 9. Loosen and raise the bottom roller assemblies so that the rollers fully capture the bottom track. There should be a 1" clearance from the roller assembly bottom support to the underside of the track.
 10. Adjust the rollers in and out so that you maintain a 1/2" clearance between the rollers and bottom gate track.
 11. Roll the cantilever gate open and close to be sure it does not interfere with the bottom roller assemblies and roller. If it does, adjust accordingly. If it does not, tighten the rollers and assembly to the post.
 12. PalmSHIELD includes touch-up paint. Closely inspect your installation for any chips or scratches. Hold the can 6" to 8" from the area to be painted and sweep across it until entirely covered. The paint will blend with the powder coated surface.

Commercial cantilever slide gate tools required

- Socket set
- Set of open end wrenches.
- Hammer drill bits for anchors. To be determined by contractor.
- 1 1/2" hammer drill or core bit for drop rods (if required).
- Hammer drill bits.
- Level
- Marking tape or paint
- String line.
- Rubber mallet



Tiger Solid Aluminum Slide

Gates Coating Standards

Technical Data

PROCESS

PalmSHIELD powder coating process and standards are based on a three-step process.

Step 1. Removal of oil, dirt, lubrication greases, metal oxides, welding scale etc. is essential prior to the powder coating process. PalmSHIELD utilizes both phosphates spray application and sweep blasting the surface. The use of a phosphate spray consist of degreasing, etching, de-smutting, various rinses and the final phosphating of the substrate. The pre-treatment process both cleans and improves bonding of the powder to the metal. Blast media and blasting abrasives are used to provide surface texturing and preparation, etching, finishing, and degreasing.

Step 2. Applying the powder. The most common way of applying the powder coating to metal objects is to spray the powder using an electrostatic gun. The gun imparts a negative charge to the powder, which is then sprayed towards the grounded object by mechanical or compressed air spraying and then accelerated toward the workpiece by the powerful electrostatic charge.

Step 3. Curing the powder. When a thermosetting powder is exposed to elevated temperature, it begins to melt, flows out, and then chemically reacts to form a higher molecular weight [polymer](#) in a network-like structure.

STANDARDS

PalmSHIELD meets and exceeds the following standards for applying our factory finish to aluminum fence panels, posts and gates to receive a polyester powder coating.

Polyester powder coating:

Electrostatically applied colored polyester powder coating heat cured to chemically bond finish to metal substrate.

Minimum hardness measured in accordance with ASTM D3363 2H.

Direct impact resistance tested in accordance with ASTM D2794. Withstand 160 inch-pounds.

Salt spray resistance tested in accordance with ASTM B117: No undercutting, rusting, or blistering after 500 hours in 5 percent salt spray at 95° F and 95% relative humidity after 1,000 hours, less than 3/16 inches undercutting.

Weatherability tested in accordance with ASTM D822: No film failure and 88 percent gloss retention after 1 year exposure in South Florida with test panels tilted 45°.

PRODUCT

PalmSHIELD uses only the highest quality products. Using PPG, Peridium TGIC Polyester powder coatings offering excellent application and performance characteristics. Peridium's tightly controlled particle size distribution provides extremely good first pass transfer efficiencies and edge coverage along with the smoothest film available. Long term exterior durability, high performance mechanical properties and overbake resistance are also common characteristics of these premium TGIC polyester coating

Cured Film Properties:

PCI Powder Smoothness Rating 8-9 (high gloss)
Specific Gravity (ASTM D792) 1.2 to 1.8 Adhesion (ASTM D3359) 5B (100%)
Gloss (ASTM D523) 30-99
Pencil Hardness (ASTM D3363) H-4H Impact (ASTM D2794) 160 - 240+ inch lbs.
Flexibility (ASTM D522) 1/8 inch - No fracturing
Humidity (ASTM D2247) 1,000+ hours
Salt Spray (ASTM B117) 1,000+ hours



Tiger Solid Aluminum Slide
Gate Continued Product
Care Technical Data

PalmSHIELD Tiger Solid Aluminum Slide Gates should not further maintenance and care beyond customers best intentions to clean the product.

In the event you do wish to wash the product, we recommend using a high quality car wash soap or nonabrasive dish wash soap.

Using a nonabrasive wash mitt or sponge, gently scrub the product back and forth to remove any dust or debris. Once finished, gently hose off the remaining soap.

Do not use a power washer, abrasive tools, or scrapers.